

GFX 50s Specification

Model name	FUJIFILM GFX 50s	
Number of effective pixels	51.4 million pixels	
Image sensor	43.8mm×32.9mm Bayer array with primary color filter	
Sensor Cleaning System	Ultra Sonic Vibration	
Storage media	SD Card (2GB) / SDHC Card (32GB) / SDXC Card (256GB) UHS-I / UHS-II*	
File format	Still Image	JPEG (Exif Ver.2.3)**, RAW : 14bit RAW (RAF original format), RAW+JPEG, 8-bit TIFF (In-camera Raw Conversion Only)
	Movie	MOV (MPEG-4 AVC / H.264)
Number of recorded pixels	[L] <4:3> 8256×6192 <3:2> 8256×5504 <16:9> 8256×4640 <1:1> 6192×6192	
	<65:24> 8256×3048 <5:4> 7744×6192 <7:6> 7232×6192	
	[S] <4:3> 4000×3000 <3:2> 4000×2664 <16:9> 4000×2248 <1:1> 2992×2992	
	<65:24> 4000×1480 <5:4> 3744×3000 <7:6> 3504×3000	
Lens Mount	FUJIFILM G mount	
Sensitivity	Standard Output	AUTO1/AUTO2/AUTO3 (up to ISO12800) / ISO100-12800 (1/3 step)
	Extended Output	ISO50 / 25600 / 51200 / 102400
Exposure control	TTL 256-zone metering, Multi / Spot / Average / Center Weighted	
Exposure mode	P (Program AE) / A (Aperture Priority AE) / S (Shutter Speed Priority AE) / M (Manual Exposure)	
Exposure compensation	-5.0EV - +5.0EV 1/3EV step (Movie: -2.0EV - +2.0EV)	
Image Stabilizer	Supported with OIS type lenses	
Shutter type	Focal Plane Shutter	
Shutter speed	Mechanical Shutter	4sec. - 1/4000sec. (P mode), 60min. - 1/4000sec. (All modes)
		Bulb mode (up to 60min.), TIME: 60min. - 1/4000sec.
	Electronic Shutter**	4sec. - 1/16000sec. (P mode), 60min. - 1/16000sec. (All modes)
		Bulb mode (up to 60min.), TIME: 60min. - 1/16000sec.
	Electronic Front Curtain Shutter**	4sec. - 1/4000sec. (P mode), 60min. - 1/4000sec. (All modes)
		Bulb mode (up to 60min.), TIME: 60min. - 1/4000sec.
	Mechanical + Electronic Shutter	4sec. - 1/16000sec. (P mode), 60min. - 1/16000sec. (All modes)
		Bulb mode (up to 60min.), TIME: 60min. - 1/16000sec.
	Electronic Front Curtain Shutter** + Electronic Shutter	4sec. - 1/16000sec. (P mode), 60min. - 1/16000sec. (All modes)
		Bulb mode (up to 60min.), TIME: 60min. - 1/16000sec.
Synchronized shutter speed for flash		1/125sec. or slower
Continuous shooting	Approx. 3.0fps (JPEG: Endless Lossless compression RAW: 13 Frames Uncompressed RAW: 8 Frames) *When Using the Electronic Front Curtain Shutter Approx. 1.8fps (JPEG: Endless Lossless Compression RAW: Endless Uncompressed RAW: 8 Frames) *Recordable frame depends on recording media. *Speed of continuous shooting depends on shooting environment and shooting frames.	
Auto bracketing	AE Bracketing (2/3/5/7/9 frames) ±1/3EV - +3EV, 1/3EV step Film Simulation Bracketing (Any 3 types of film simulation selectable) Dynamic Range Bracketing (100%, 200%, 400%) ISO sensitivity Bracketing (±1/3EV, ±2/3EV, ±1EV) White Balance Bracketing (±1, ±2, ±3)	
Focus	Mode	Single AF / Continuous AF / MF
	Type	TTL Contrast AF
AF frame selection	Single Point AF: EVF / LCD: 13×9 / 25×17 (Changeable Size of AF Frame Among 6 Types)	
	Zone AF: 3×3 / 5×5 / 7×7 from 117 Areas on 13×9 Grid Wide/Tracking AF: (Up to 9 Area) *AF-S: Wide *AF-C: Tracking	
White balance	Automatic scene recognition / Custom / Color temperature selection (K) / Preset : Daylight, Shade, Fluorescent light (Daylight), Fluorescent light (Warm White), Fluorescent light (Cool White), Incandescent light, Underwater	
Self-timer	10sec. / 2sec.	
Interval timer Shooting	YES Setting : Interval, Number of shots, Starting time	
Flash modes	SYNC. MODE	1ST CURTAIN / 2ND CURTAIN / AUTO FP(HSS)
Hot shoe	*When EF-X500 is set	FLASH MODE
		TTL_FLASH AUTO / STANDARD / SLOW SYNC.) / MANUAL / OFF
Viewfinder	Yes (Dedicated TTL Flash compatible)	
	0.5 inch Approx. 3.69 millions dots OLED Color Viewfinder	
	Coverage of Viewing Area vs. Capturing Area: Approx. 100%	
	Eyepoint: Approx. 23mm (from the Rear End of the Camera's Eyepiece)	
	Dioptr Adjustment: -4 - +2m ⁻¹ Magnification: 0.85x with 50mm Lens (50mm Equivalent) at infinity and Dioptr set to -1.0m ⁻¹ Diagonal Angle of View: Approx. 40° (Horizontal Angle of View: Approx. 33°) Built-In Eye Sensor	

*1 Please see the Fujifilm website to check memory card compatibility. *2 Exif 2.3 is a digital camera file format that contains a variety of shooting information for optimal printing. *3 The Electronic Shutter may not be suitable for fast-moving objects. Flash can not be used. *4 When using the electronic front curtain shutter, the continuous shooting speed drops and using high speed shutter, the shutter switches to mechanical shutter. (1/640sec. to 1/4000sec.) *5 Approximate number of frames or movie recording time that can be taken with a fully-charged based on CIPA Standard.

Memory Card Capacity and Image Quality / Size

Still Image	8GB	RAW 66 / RAW (Lossless compressed) 127 / L (4:3 / SUPER FINE) 254 / L (4:3 / FINE) 381 / L (4:3 / NORMAL) 607
Number of images	16GB	RAW 137 / RAW (Lossless compressed) 265 / L (4:3 / SUPER FINE) 524 / L (4:3 / FINE) 785 / L (4:3 / NORMAL) 1253

LCD monitor		3.2 inch, Aspect Ratio 4:3, Approx. 2.360K-dot Tilt-Type, Touch Screen Color LCD Monitor (Approx. 100% Coverage)
	Sub LCD monitor	1.28 inch, Aspect Ratio 1:1, 128×128-dot Monochrome LCD Monitor
Movie recording		[Full HD (1920×1080)] 29.97p / 25p / 24p / 23.98p 36Mbps up to Approx. 30min. [HD (1280×720)] 29.97p / 25p / 24p / 23.98p 18Mbps up to Approx. 30min.
	Photography functions	Color, Sharpness, Highlight tone, Shadow tone, Noise reduction, Long exposure NR, Lens Modulation Optimizer, Color space, Pixel mapping, Select custom setting, Edit/Save custom setting, Store AF mode by orientation, Rapid AF, AF point display, Pre-AF, Face/Eye detection AF, AF+MF, Focus peak highlight, Focus check, Interlock spot AE & focus area, Instant AF setting (AF-S/AF-C), Depth-of-field scale, Release/Focus priority, Touch screen mode, Mount adapter setting, Red eye removal, Movie AF mode, RGB Histogram, Highlight alert, Electronic level, Preview depth of field, AE lock, AF lock, AF-ON, Multiple exposure
Touch Screen Mode	Shooting Mode	Touch AF, Focus Area, OFF
	Playback Mode	Swipe, Zoom, Pinch-in / Pinch-out, Double-tap, Drag
Film Simulation mode		15 modes (PROVIA / Standard, Velvia / Vivid, ASTIA / Soft, Classic Chrome, PRO Neg.Hi, PRO Neg.Std, Black&White, Black&White+Ye Filter, Black&White+R Filter, Black&White+Gfilter, Sepia, ACROS, ACROS+Ye Filter, ACROS+R Filter, ACROS+G Filter)
Grain Effect		STRONG, WEAK, OFF
Color Chrome Effect		STRONG, WEAK, OFF
Dynamic range setting		AUTO, 100%, 200%, 400%
Playback functions		Switch slot, RAW conversion, Erase, Erase selected frames, Crop, Resize, Protect, Image rotate, Red eye removal, Voice memo setting, Copy, Photobook assist, Multi-frame playback (with micro thumbnail), Favorites, RGB histogram, Highlight alert
	Wireless transmitter	Standard IEEE 802.11b/g/n (standard wireless protocol) Access mode Infrastructure Encryption WEP / WPA / WPA2 mixed mode
Wireless function		Geotagging, Wireless communication (Image transfer), View & Obtain Images, Remote camera shooting, instax printer print
Other functions		Exif Print, Date/Time, Time difference, 35 Languages, My menu setting, Sensor cleaning, Battery age, Sound set-up, EVF brightness, EVF color, LCD brightness, LCD color, Image disp, Auto rotate displays, Preview exp./WB in manual mode, Preview pic. effect, Framing guideline, Autorotate PB, Focus scale units, Disp. custome setting, Sub monitor setting, Focus lever setting, Edit/Save Quick menu, Function(Fn) setting, Selector button setting, Command dial setting, Shutter AF, Shutter AE, Shoot without lens, Focus ring, AE/AF-Lock mode, Expo. Comp. button setting, Touch screen setting, Lock, Auto power off, Shooting stand by mode, Auto power save, Frame No., Save org image, Edit file name, Card slot setting, Switch slot, Movie file destination, Copyright info
	Terminal	Digital interface USB3.0 (High-Speed) / micro USB terminal *connectable with Remote Release RR-90 (sold separately) HDMI output HDMI Micro connector (Type D) Others ø3.5mm, stereo mini connector (Microphone) ø3.5mm, stereo mini connector (Headphone) ø2.5mm, Remote Release Connector DC IN 15V Connector *Compatible with AC-15V (Optional) Only Hot shoe Synchronized terminal
Power supply		NP-T125 Li-ion battery (included) Battery life for still images** Approx. 400 frames When GF63mmF2.8 R WR is set. (Auto power save ON) Continuous battery life of movie capture** [Full HD] Approx. 145min. *Face detection is set to OFF Actual battery life of movie capture** [Full HD] Approx. 70min. *Face detection is set to OFF
Dimensions		147.5mm (W) × 94.2mm (H) × 91.4mm (D) / 5.81in. (W) × 3.71in. (H) × 3.60in. (D) (Minimum Depth : 41.6mm / 1.64in.)
Weight		Approx. 825g / 29.1oz. (including battery and memory card) Approx. 920g / 32.5oz. (including EVF)
		Approx. 740g / 26.1oz. (excluding accessories, battery and memory card)
Operating Temperature		-10°C - 40°C (+14°F - +104°F)
Operating Humidity		10% - 80% (no condensation)
Starting up period		Approx. 0.4sec. *Fujifilm Research
Accessories included		Li-ion battery NP-T125, Battery charger BC-T125, Plug adapter, Body cap, Shoulder strap, Metal strap clip, Metal strap clip lock, Cable protector, Interchangeable electronic viewfinder EVF-GFX1, Hot shoe cover (Body/EVF), Connector cover (EVF), Vertical Battery Grip connector cover, Sync terminal cover, Owner's manual

Movie	8GB	Full HD (1920×1080) 26min. / HD (1280×720) 51min.
Recording time	16GB	Full HD (1920×1080) 54min. / HD (1280×720) 105min.

FUJIFILM

Value from Innovation

Medium Format Mirrorless Digital Camera **GFX 50s** | SYSTEM BROCHURE



GFX

<http://fujifilm-x.com/gfx-50s/>

To ensure correct usage, read owner's manual carefully before using your equipment.
All photos, illustrations, drawings and other images in this brochure are intended for illustrative purposes only.

SDXC logo is a trademark. All other trademarks are the property of their respective holders.
SILKYPIX® is a registered trademark of Ichikawa Soft Laboratory Co., Ltd. in Japan.

Specifications are subject to change without notice

For more information, please visit our website

http://www.fujifilm.com/products/digital_cameras/index.html

FUJIFILM
FUJIFILM Corporation

©2017 FUJIFILM Corporation



OPEN YOUR EYES

FUJIFILM GFX 50s

The FUJIFILM GFX 50S delivers the world's best image quality. It combines outstanding resolution of 51.4 megapixels with exceptional tones, advanced color reproduction and high-performance lenses. This level of image quality is purely motivational. The world around you changes the moment you hold this camera in your hand. Appreciate all that can be achieved with Fujifilm's new medium format mirrorless camera system, GFX.

SEE MORE OF THE WORLD

FUJIFILM GFX 50S

Fujifilm has always prioritized image quality in its medium format film cameras. Now, after establishing a solid market position in digital imaging, the company is returning to the world of medium format with the launch of the GFX 50S. By using in-depth knowledge of larger format cameras and applying the same philosophy that has run throughout the development of Fujifilm's digital photographic equipment, this camera achieves new standards in photographic quality. The GFX 50S begins a new chapter in camera history.











FUJIFILM GFX 50s

● CONTENTS

PAGE	SPECIFICATION
13	• SENSOR
	• PROCESSOR
14	• MOUNT
	IMAGE QUALITY
15	• IMAGE SETTINGS / BASICS
16	• ADVANCED IMAGE SETTING
	BODY / DEVICE
17	• BODY
18	• VIEWFINDER
19	• LCD MONITOR
20	• SUB MONITOR
	• VERTICAL BATTERY GRIP
	MECHANICAL
21	• SHUTTER
	• FOCUSING
	OPERABILITY
22	• EXPOSURE
	• PHOTOMETRY
	• CONTINUOUS SHOOTING
	• FLASH SHOOTING
23	• VARIOUS FUNCTIONS
	LENS
25	• FUJINON GF LENS
	SYSTEM
27	• FLASH
	• TERMINAL
28	• MOUNT ADAPTER
	• VIEW CAMERA ADAPTER
29	• TETHERED SHOOTING
	• RAW CONVERSION
31	• SYSTEM CHART

● SENSOR

FUJIFILM G Format Image Sensor The GFX 50S features a 43.8x32.9mm CMOS medium format sensor: a product of Fujifilm's rich history, cutting-edge digital technology and extensive knowledge of medium format film cameras. Boasting an effective resolution of 51.4 million pixels and paired with high-performance GF lenses, the sensor delivers superior tones and sharpness that will impress professional photographers shooting in the world of commercial, fashion or landscapes.

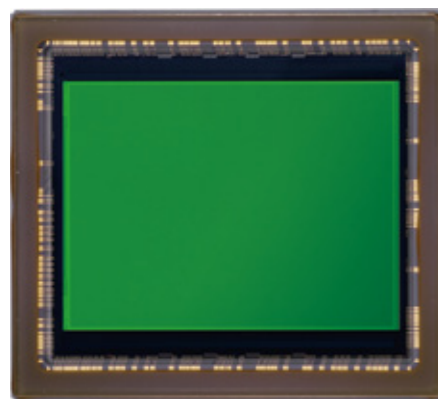

Actual size

FUJIFILM G FORMAT	
43.8x32.9mm	
35mm FORMAT	
[FULLFRAME] 36.0x24.0mm	
APS-C FORMAT	
23.6x15.6mm	

Number of effective pixels	51.4 Million Pixels
Image sensor	43.8mmx32.9mm (FUJIFILM G Format) CMOS with Primary Color Filter No Optical Low-Pass Filter
Number of Recorded Pixels	[L] <4:3> 8256x6192

Optimized Sensor Design Both the shape of the light-gathering micro-lenses and the processing from the photodiodes have been optimized to achieve a high level of sharpness and broad dynamic range. The lowest native ISO sensitivity of 100 and the 14-stop dynamic range, achieved with 14-bit RAW data, delivers high definition images in a variety of conditions with notably rich skin tones and intricate foliage detail.

● PROCESSOR

FUJIFILM X-Processor Pro The GFX 50S sports the X-Processor Pro image processing engine, capable of drawing the very best out of the 51.4 megapixel sensor. Its advanced processing accelerates and optimizes the camera's performance in a variety of areas including stunning color reproduction with Fujifilm's unique Film Simulation modes, in-camera RAW conversion to the 8-bit TIFF format, accurate contrast AF, quick startup time, and minimal shutter release time lag and shooting intervals between frames.

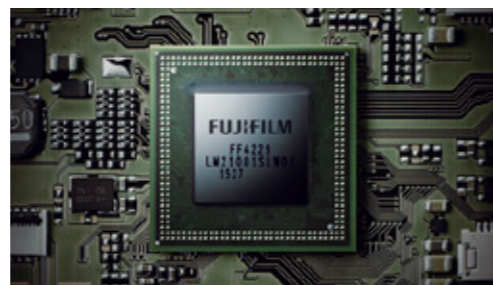

● MOUNT

FUJIFILM G MOUNT The GFX 50S uses the G Mount, which has a mount diameter of 65mm, flange back distance of 26.7mm and minimum back focus distance of 16.7mm. It uses as many as 12 electronic contact points for sending and receiving data, plus it supports the use of a wide variety of lenses and accessories. The short back focus distance, made possible because of the Fujifilm mirrorless system's structure, affords greater freedom in lens design to contribute to the development of fast, compact and high-performance GF lenses while preventing vignetting to deliver edge-to-edge sharpness.

G MOUNT



Actual size

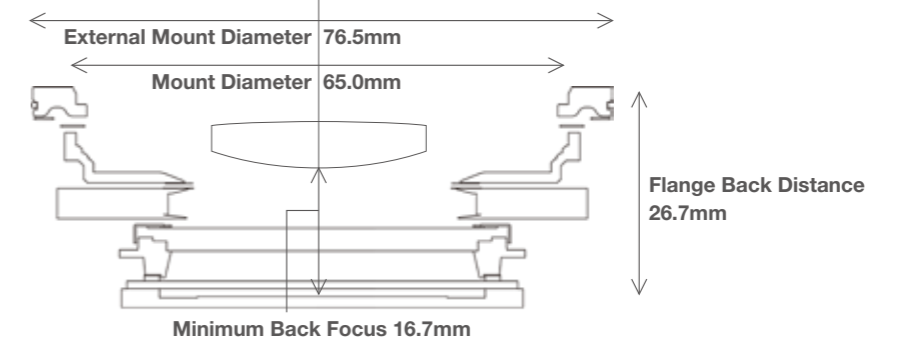

Electronic Contact	12 pins
Sensor Cleaning	Ultra Sonic Vibration

IMAGE SETTINGS / BASICS

Image Formats The GFX 50S saves pictures in a variety of formats and quality, including two sizes and three compression levels of JPEGs, as well as compressed/uncompressed RAW. Even when you are shooting only in RAW, the camera records 12-megapixel thumbnails at the same time. Its in-camera RAW conversion function also enables RAW files processing with the ability to save them as 8-bit TIFFs.

Compressed	JPEG (EXIF Ver.2.3)*
Uncompressed	RAW: 14bit RAW (RAF Original Format), RAW+JPEG 8bit TIFF (In-Camera Raw Conversion Only)

Aspect Ratio

4:3 (L) 7744x6192 (48M) (S) 3744x3000 (11M)	5:4 (L) 7744x6192 (48M) (S) 3744x3000 (11M)	7:6 (L) 7232x6192 (45M) (S) 3504x3000 (11M)	1:1 (L) 6192x6192 (38M) (S) 2992x2992 (9M)
3:2 (L) 8256x5504 (45M) (S) 4000x2664 (11M)	16:9 (L) 8256x4640 (38M) (S) 4000x2248 (9M)	65:24 (L) 8256x3048 (25M) (S) 4000x1480 (6M)	

*Exif 2.3 is a digital camera file format that contains a variety of shooting information for optimal printing.

ISO Sensitivity The standard ISO sensitivity range is ISO100-12800, with extended sensitivities of ISO50, ISO25600, ISO51200 and ISO102400 also available. RAW format is supported at all these ISO settings. The AUTO function allows you to set the standard ISO, low shutter speed limit and upper ISO limit, and configure AUTO 1 - 3 settings according to shooting conditions.

Standard Output	AUTO1 / AUTO2 / AUTO3 (up to ISO12800) / ISO100 to 12800 (1/3 step)
Extended Output	ISO50 / 25600 / 51200 / 102400

White Balance White balance can be set as Auto, Preset, Custom or Color Temperature settings. RB color coordinates can be used to shift the white balance for fine tuning color balance. Up to three custom white balance settings can also be stored.

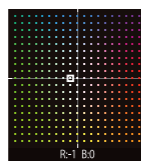

Automatic Scene Recognition, Custom 1-3
 Color Temperature Selection (2500K - 10000K)
 Preset: Daylight, Shade, Fluorescent Light (Daylight), Fluorescent Light (Warm White), Fluorescent Light (Cool White), Incandescent Light, Underwater

Other Image Quality Settings Tones and colors can be fine tuned in combination with Film Simulation to achieve your desired color reproduction.

Dynamic Range	AUTO-100%-200%-400%
Highlight Tone	+4~-2
Shadow Tone	+4~-2
Color	+4~-4
Sharpness	+4~-4
Noise Reduction	+4~-4

ADVANCED IMAGE SETTING

FILM SIMULATION Developed with Fujifilm's color producing know-how over 80 years of photographic film manufacturing, Film Simulation allows you to reproducing a variety of colors and tones as if using different photographic films.



PROVIA

Standard mode for general use that faithfully reproduces 'memory colors'; colors just as you remember them.



Velvia

A combination of high saturation and 'memory colors', this option reproduces vivid colors, making it ideal for landscapes.



ASTIA

Combining a soft effect with high saturation, this option delivers radiant skin tones and smooth gradation.



CLASSIC CHROME

Delivering subtle colors and beautifully muted tones, this simulation is reminiscent of vintage reversal film.



PRO Neg. Hi

Produce portraits with sharp contrast even in flat light. This option delivers natural skin tones, setting it apart from those based on 'memory color' technology.



PRO Neg. Std

Reproduces accurate, natural skin tones in portraits shot under controlled light.

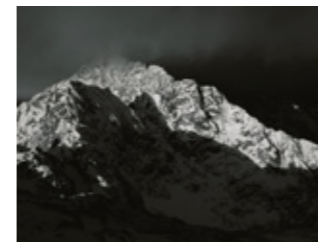

ACROS

Premium monochrome mode delivers fine texture, deep blacks and smoother tones.

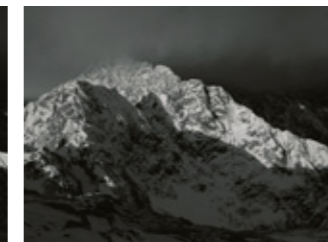

MONOCHROME

General use monochrome mode that offers three filter options (Ye, R and G), just like ACROS.



SEPIA

Adds a warm tone across the frame for a sepia look. When applied to a retro subject, it creates a nostalgic look.

GRAIN EFFECT Graininess is added to the entire frame to simulate the look of film-based images.



Grain Effect OFF / Weak / Strong

COLOR CHROME EFFECT Provides an extra boost to saturated colors for a more punchy result.

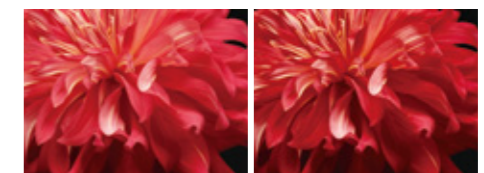

Color Chrome Effect OFF / Weak / Strong

GFX 50s

BODY / DEVICE

BODY



Actual size

Dust-resistant, water-resistant and freezeproof to -10° C. The body is made from robust magnesium alloy, which feels both solid and durable in the hand. The body is weather-sealed in 58 points to achieve a high level of resistance to dust and moisture. The GFX 50S is compact and lightweight despite the large size of its sensor, plus its dust and weather-resistant body means it's equally effective in the studio or out in the field.

Dimensions	147.5mm (W) x 94.2mm (H) x 91.4mm (D) (Minimum Depth 41.6mm)
Weight	Approx. 825g (including Battery and Memory Card), Approx. 920g (including EVF)
Body	Magnesium Alloy
Operating Condition	Temperature -10°C - 40°C / Humidity 10 - 80% (No Condensation)



Drive Menu Use the Drive button to quickly switch between different modes such as Burst, Bracketing and Video.

Still Image / Continuous / AE BKT / ISO BKT /
Film Simulation BKT / White Balance BKT /
Dynamic Range BKT / Multiple Exposure / Movie

Command Position (C/T) Set the ISO Dial / Aperture Ring to "C" and the Shutter Speed Dial to "T" to change settings only with the front and rear Command Dials while checking settings on the Sub LCD Monitor.

Dual Card Slot Both slots support high-speed UHS-II cards. They can be assigned to store files according to their format, e.g. JPEG, RAW or Movie.

SD Card (-2GB) / SDHC Card (-32GB) / SDXC Card (-256GB)
UHS-I / UHS-II*

* Please see the Fujifilm website to check memory card compatibility.

Exposure Compensation Exposure compensation of up to ±5 stops in 1/3 steps can be set with the Exposure Compensation Button and Rear Command Dial.

Still Image	-5.0EV - +5.0EV, 1/3EV Step
Movie Recording	-2.0EV - +2.0EV

BODY / DEVICE

GFX 50s

BODY / DEVICE

VIEWFINDER



Actual size

High Magnification and High Definition Electronic Viewfinder

The GFX 50S is supplied with a detachable 3.69M-dot EVF with 100% coverage and a viewfinder magnification of 0.85x. It uses five dedicated lens elements to achieve 100% coverage and offers a diopter adjustment range of -4m⁻¹ to +2m⁻¹.

Finder	0.5 inch Approx. 3.69 millions dots OLED Color Viewfinder Coverage of Viewing Area vs. Capturing Area: Approx. 100%
Eyepoint	Approx. 23mm (from the Rear End of the Camera's Eyepiece)
Diopter Adjustment	-4 - +2m ⁻¹
Magnification	0.85x with 50mm Lens (35mm Equivalent) at infinity and Diopter set to -1.0m ⁻¹
Diagonal Angle of View	Approx. 40° (Horizontal Angle of View: Approx. 33°)
EVF Brightness	AUTO / -5 - +5 EVF Color -5 - +5
Others	Built-In Eye Sensor



EVF Tilting Adapter EVF-TL1 (Optional) Attach the optional EVF Tilting Adapter EVF-TL1 between the camera body and the EVF to enable vertical tilt (0°-90° / 5 steps) and horizontal rotation (±45°). This allows you to shoot from waist level or aids shooting in portrait orientation.

Dimensions	53.7mm (W) x 36.8mm (H) x 65.3mm (D)
Weight	Approx. 160g (Aluminium)
Operating Temperature	-10°C - 40°C
Operating Humidity	10 - 80% (No Condensation)
Operation Parts	Hot Shoe / Tilting Lock / Lock Release Button / Rotating Lock Lever



3D Electronic Level This electronic level uses a 3D system and is highly effective for architecture or landscape photography, when the accuracy of horizontal and vertical lines is crucial.

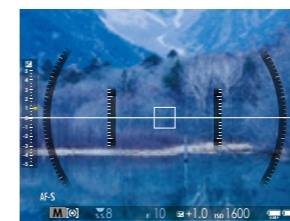

RGB Histogram The GFX 50S can display four types of histograms: RGB and brightness, each with or without highlight warnings.

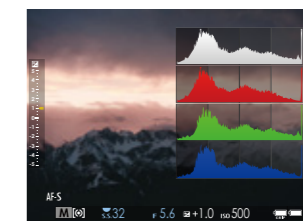

BODY / DEVICE

LCD MONITOR

Large Rear Touchscreen LCD Tilts in Three Directions The rear 2.36M-dot LCD monitor measures 3.2 inches and offers 100% coverage. The smart touchscreen panel enables intuitive operation and tilts in three directions (90° up, 45° down and 60° to the right) for easy framing and shooting from high or low angles.



Monitor	3.2 inch, Aspect Ratio 4:3, Approx. 2,360K-dot Tilt-Type, Touch Screen Color LCD Monitor (Approx. 100% Coverage)
LCD Brightness	AUTO -5 - +5 (30 - 800cd/m ²)
LCD Color	-5 - +5



Actual size

Enlarged Live View For more accurate focusing, push or rotate the Rear Command Dial to enlarge Live View images between 1x and 16.7x.

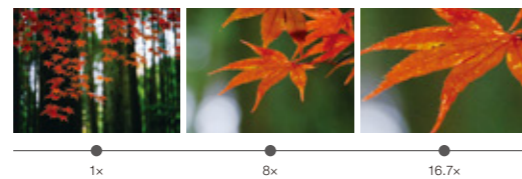

Smart Touchscreen Display The GFX 50S features a smart touchscreen display, which makes it easy to select an AF area, bring up an RGB histogram, display the 3D electronic level and enlarge the Live View.

Shooting Mode / Playback Mode	Flick (Up and Down)	RGB Histogram, Live View Highlight Alert (Shooting Mode only)
	Double Tap	Enlarged Live View / Playback Zoom
	Tap, Press, Drag	AF Area Selection, Touch AF / View Other Area During Playback Zoom
	Pinch-In, Pinch-Out	Playback Zoom In and Out (Playback Mode only)
Other Functions	Swipe	View Next Picture (Playback Mode only)
	Q Menu Selection, Input Character	



SUB MONITOR



Sub LCD Monitor displays main settings The 1.28-inch monochrome LCD monitor can be viewed in all conditions (including bright sunlight) and displays information including shutter speed, aperture, ISO, exposure compensation and exposure mode. You can customize up to eight items to be displayed on the monitor; it also has a backlight for viewing in low light conditions.

1.28 inch, Aspect Ratio 1:1, 128x128-dot Monochrome LCD Monitor

Backlight: Yes

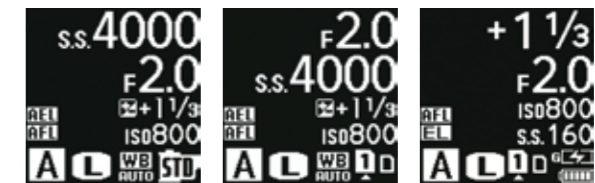

VERTICAL BATTERY GRIP



Vertical Battery Grip VG-GFX1 (Optional) The vertical battery grip VG-GFX1 provides a solid grip while also maintaining the camera's optical axis during vertical shooting. The grip features a Shutter Release Button, Command Dial, Focus Lever and six Fn buttons, mirroring the layout of the camera body. It holds an extra battery to enable shooting for extended periods of time and can be used to charge the battery. Using the AC adapter supplied (AC-15V), you can fully charge a battery in approx. two hours.

Dimensions	147.5mm (W) x 52.1mm (H) x 67.9mm (D)
Weight	Approx. 310g (Magnesium Alloy, Excluding battery)
Operating Temperature	-10°C - 40°C
Operating Humidity	10 - 80% (No Condensation)
Operation Parts	Shutter Button, Control Lock, Front and Rear Command Dial, Fn Buttons 1-6, Focus Lever, Q Button, MENU/OK Button, Battery Cover Lock, Tripod Socket, Lock Screw

SHUTTER

The World's First Focal-Plane Shutter*1 Specifically Designed for Medium Format Mirrorless Cameras The newly-developed focal-plane shutter is the world's first specifically designed for medium format mirrorless cameras. It is a low-noise mechanical shutter that withstands 150,000 actuations*2, offers shutter speeds up to 1/4000sec. and has an electronic first curtain. Choose from three shutter types, including an electronic shutter.

*1 Fujifilm research as of December 2016. Compared with other mirrorless digital cameras equipped with 43.8x32.9mm sensor or larger. *2 According to Fujifilm internal testing.

Mechanical Shutter	Mechanical + Electronic Shutter
4sec. to 1/4000sec. (P Mode), 60min. to 1/4000sec. (All Modes)	4sec. to 1/16000sec. (P Mode), 60min. to 1/16000sec. (All Modes)
Bulb mode (up to 60min.), TIME: 60min. to 1/4000sec.	Bulb Mode (up to 60min.), TIME: 60min. to 1/16000sec.
Electronic Front Curtain Shutter*	Electronic Front Curtain Shutter + Electronic Shutter
4sec. to 1/4000sec. (P Mode), 60min. to 1/4000sec. (All Modes)	4 sec. to 1/16000sec. (P Mode), 60min. to 1/16000sec. (All Modes)
Bulb Mode (up to 60min.), TIME: 60min. to 1/4000sec.	Bulb Mode (up to 60min.), TIME: 60min. to 1/16000sec.
Electronic Shutter	Synchronized Shutter Speed for Flash
4sec. to 1/16000sec. (P Mode), 60min. to 1/16000sec. (All Modes)	1/125 sec. or slower
Bulb Mode (up to 60min.), TIME: 60min. to 1/16000sec.	

FOCUSING

9x13 (117 Points) / 17x25 (425 Points) Single Focus Points and Six Sizes of Focus Area TTL Contrast AF is available in Single Point, Zone and Wide/Tracking modes. In the Single Point mode, the camera offers 9x13 (117 points) or 17x25 (425 points) and six different Focus Area sizes. Select the minimum size for pinpoint focusing.

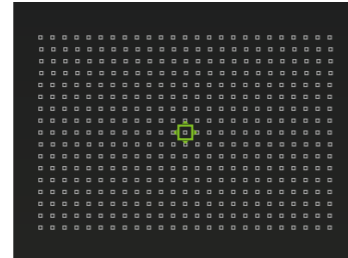

Focus Mode	Single AF / Continuous AF / MF
Auto Focus Type	TTL Contrast AF
AF Frame Selection	Single Point AF: EVF / LCD: 13x9 / 25x17 (Changeable Size of AF Frame Among 6 Types) Zone AF: 3x3 / 5x5 / 7x7 from 117 Areas on 13x9 Grid Wide/Tracking AF: (Up to 9 Area) *AF-S: Wide *AF-C: Tracking

Six AF Modes

AF-S + Single Point	For capturing subjects using a specific AF point	AF-C + Single Point	For continuous spot-focusing
AF-S + Zone	For capturing subjects across a large AF area (3x3, 5x5, 7x7)	AF-C + Zone	For tracking a subject within a selected area
AF-S + Wide	For automatically capturing a subject across the frame	AF-C + Tracking	For continuously tracking a subject across the frame

Focus Lever Use the Focus Lever to move the focus area in eight directions (up/down, side to side, diagonally) for easy framing and accurate focusing.



Face Detection / Eye Detection AF The camera automatically detects and focuses on a face or eyes. Priority can be given to either the right or left eye.

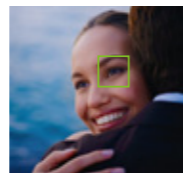

Depth of Field Scale The distance indicator bar on the monitor can be used to check depth of field. Choose between the Pixel Basis and Film Format Basis options.

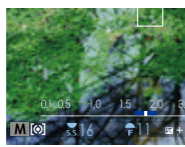

Focus Assist Function Use the Focus Peaking function in Manual Focus mode. The Live View on the screen can be enlarged for more accurate focusing.



EXPOSURE

Exposure Mode Settings Using Dials and Rings The combination of settings on the Shutter Speed Dial, ISO Dial and Aperture Ring allow you to switch between four different exposure modes: Aperture Priority AE (A), Shutter Speed Priority AE (S), Program AE (P) and Manual. As dials are used for main exposure settings, you can adjust settings even when the camera is turned off. The Command Position (C/T) also enables Command Dial operations.



PHOTOMETRY

Four Metering Modes The GFX 50S offers four metering modes: Multi, Spot, Average and Center Weighted. When spot metering, the focusing and metering areas can be linked.

Multi	Calculates exposure based on analysis of the whole frame	Average	Sets exposure based on the average brightness of the entire frame
Spot	Takes a meter reading from an area occupying approx. 2% of the frame	Center Weighted	Takes a meter reading mainly from the center of the frame

CONTINUOUS SHOOTING

Continuous Shooting at Approx. 3.0fps In continuous shooting mode, the GFX 50S can shoot at up to 3.0fps until the memory card fills up in JPEG, up to 8 frames in RAW, and up to 13 frames in compressed RAW.

Approx. 3.0 fps (JPEG: Endless, Lossless Compression RAW: 13 Frames, Uncompressed RAW: 8 Frames)

Approx. 1.8 fps (JPEG: Endless, Lossless Compression RAW: Endless, Uncompressed RAW: 8 Frames) *When Using the Electronic Front Curtain Shutter

FLASH SHOOTING

Multi-Function Flash Flash sync speed is up to 1/125sec. When using the optional EF-X500, which supports FP mode, flash sync can be as fast as 1/4000sec. (the maximum shutter speed possible with the mechanical shutter). The camera also caters to a variety of flash settings including multiple flash lighting.

Compatible Flash	Fujifilm EF Series (excluding EF-X8)
Sync Terminal	Yes Synchronized Shutter Speed for Flash 1/125sec. or Slower
SYNC. MODE	1ST CURTAIN / 2ND CURTAIN / AUTO FP (HSS)
FLASH MODE	TTL (FLASH AUTO / STANDARD / SLOW SYNC.) / MANUAL / OFF

*When EF-X500 is set.

VARIOUS FUNCTIONS

Five Types of Bracketing Five types of bracketing are available to capture multiple frames at different settings with a single press of the shutter release. This function works with both JPEG and RAW formats.

AE Bracketing (2/3/5/7/9 frames)	±1/3EV - ±3EV, 1/3EV step
Film Simulation Bracketing	Any 3 Types of Film Simulation Selectable
Dynamic Range Bracketing	100% · 200% · 400%
ISO Sensitivity Bracketing	±1/3EV / ±2/3EV / ±1EV
White Balance Bracketing	±1 / ±2 / ±3

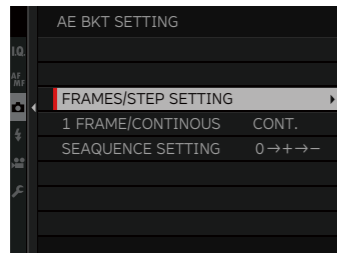

AE Bracketing

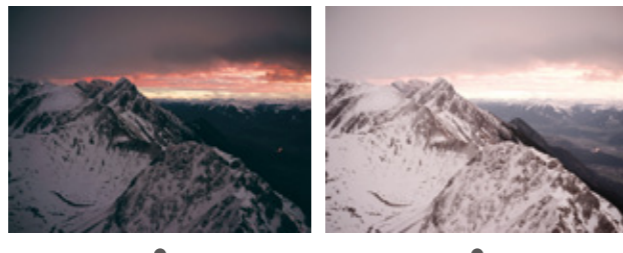

±0EV

+3EV



Film Simulation Bracketing

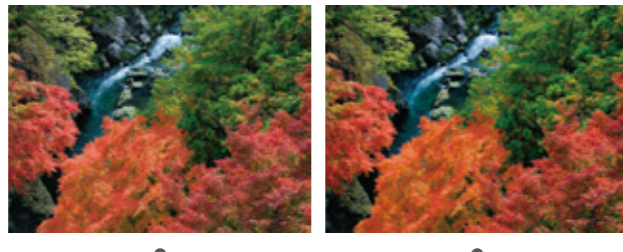

PROVIA

Velvia

Interval Timer Shooting Sample unique shooting styles including fixed-point photography, time lapse and self-timer images with controls over shooting interval, total number of frames and shutter delay. You can set an interval between 1 sec - 24 hours for shooting 1 - infinity frames.

Shooting Interval	1sec. - 24 hours
Number of Frames	1 - 999 + ∞
Shutter Delay	In 0min. - 24 hours

Self Timer The Self Timer function can be set at 2 sec or 10 sec. It is particularly useful for situations when you want to minimize camera shake, such as long exposures.

Multiple Exposure The GFX 50S allows you to take two frames and combine them for a creative effect. The first shot is displayed on the LCD monitor, so you can easily compose and shoot the second frame.

Battery Age Check the age of the batteries in the camera and the vertical battery grip. Battery age is expressed as a number between 0 (youngest) and 4 (oldest).

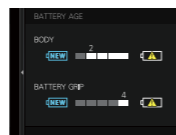

Shooting Stand By Mode In standby mode, all displays except the Sub LCD Monitor turn off to save power when no operations are being performed. Choose the length of time your camera will wait before entering standby mode: 5 min, 2 min, 1 min, 30 sec, or 15 sec.

Full HD Video The GFX 50S supports Full HD video recording (1920×1080, 29.97p / 25p / 24p / 23.98p, 36Mbps) and HD video recording (1280×720, 29.97p / 25p / 24p / 23.98p, 18Mbps). Film Simulation effects, such as ACROS for ultra high-quality monochrome and Classic Chrome for a documentary-themed look, can also be applied to video.

Movie File Format	MOV
Movie Video Compression	MPEG-4 AVC / H.264
Audio	Linear PCM / Stereo Sound 48KHz Sampling
Size (pixels) and Frame Rate	Full HD 1920×1080 29.97p / 25p / 24p / 23.98p 36Mbps up to Approx. 30min. HD 1280×720 29.97p / 25p / 24p / 23.98p 18Mbps up to Approx. 30min.
Continuance battery life of movie capture*	Full HD: Approx. 145min. *Face detection is set to OFF
Actual battery life of movie capture*	Full HD: Approx. 70min. *Face detection is set to OFF

* Approximate number of frames or movie recording time that can be taken with a fully-charged based on CIPA Standard.

Voice Memo Function Record your voice for up to 30 seconds to make notes about the images you are shooting. This makes it easy to keep track of shooting data in situations where writing notes is impractical.

Audio File Format	WAVE
Audio	Linear PCM / Stereo Sound 48KHz Sampling
Consecutive Audio Recording	30sec.

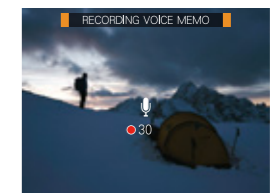

Copyright Data for EXIF Use the touchscreen panel to enter "Author" and "Copyright" to automatically add this information to the file's EXIF data.



Sensor Cleaning The GFX 50S uses piezoelectric elements to provide ultrasonic sensor cleaning. You can specify when to perform sensor cleaning: immediately, when the camera is turned on, or when the camera is turned off.

Wireless Connectivity Install the free FUJIFILM Camera Remote app on your smartphone or tablet to carry out a location data search, remotely control the camera and transfer or view in-camera images, all without having to enter a password. This functionality is also useful when shooting landscapes with the camera mounted on a tripod.



<http://app.fujifilm-dsc.com/>

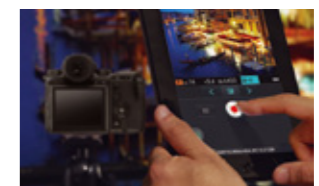

Custom Buttons and Menus The GFX 50S features 10 customizable Fn buttons. Different options can also be assigned to Short Cut Q (Quick) menu items. Frequently used settings can be registered in My Menu while Custom Registration allows you to save and rename Film Simulation and image quality settings.

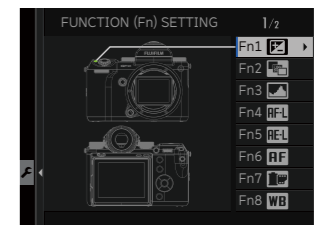

Fn Button	Camera Body 10 Buttons / Battery Grip 6 Buttons	My Menu Settings	16 Items
Q Menu	16 Menus	Custom Setting	7 Settings

● FUJINON GF LENS

High Performance FUJINON GF Lenses FUJINON lenses have long catered to the needs of professional photographers with an extensive lineup including medium format lenses, large format lenses and broadcast TV lenses. GF lenses, developed with the latest optical technologies, boast outstanding performance and image quality.

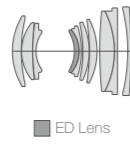

GF63mmF2.8 R WR

50mm (35mm format equivalent)

Lens configuration	10 elements in 8 groups (includes 1 extra-low dispersion elements)
Focal length (*)	f=63mm (50mm)
Angle of view	46.9°
Max. aperture	F2.8
Min. aperture	F32
Aperture control	Number of blades 9 (rounded diaphragm opening) Stop size 1/3EV (22 steps)
Focus range	0.5m - ∞
Max. magnification	0.17x
External dimension	φ84.0mm×71.0mm
Weight	405g (Excluding caps and hoods)
Filter size	φ62mm

*35mm format equivalent

GF120mmF4 R LM OIS WR Macro

95mm (35mm format equivalent)

Lens configuration	14 elements in 9 groups (includes 3 extra-low dispersion elements)
Focal length (*)	f=120mm (95mm)
Angle of view	25.7°
Max. aperture	F4
Min. aperture	F32
Aperture control	Number of blades 9 (rounded diaphragm opening) Stop size 1/3EV (19 steps)
Focus range	45cm - ∞
Max. magnification	0.5x
External dimension	φ89.2mm×152.5mm
Weight	980g (Excluding caps and hoods)
Filter size	φ72mm

*35mm format equivalent

GF32-64mm F4 R LM WR

25-51mm (35mm format equivalent)

Lens configuration	14 elements in 11 groups (includes 3 aspherical and 2 extra-low dispersion elements incl. 1 super ED lens)
Focal length (*)	f=32-64mm (25-51mm)
Angle of view	81°-46.3°
Max. aperture	F4
Min. aperture	F32
Aperture control	Number of blades 9 (rounded diaphragm opening) Stop size 1/3EV (19 steps)
Focus range	0.5m - ∞ (W) 0.6m - ∞ (T)
Max. magnification	0.12x
External dimension	φ92.6mm×116mm(W) / 145.5mm(T)
Weight	875g (Excluding caps and hoods)
Filter size	φ77mm

*35mm format equivalent

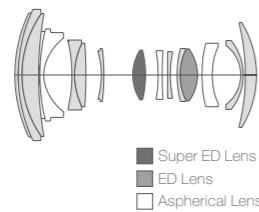
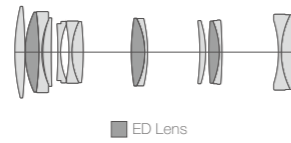

■ Super ED Lens
■ ED Lens
□ Aspherical Lens

Brass Lens Mount The lens mount is made from brass for strength, durability and reliability.



Dust-resistant, water-resistant and freezeproof to -10°C Like the camera body, GF lenses are resistant to dust, water and low temperatures. Create epic photography regardless of the weather or the season.

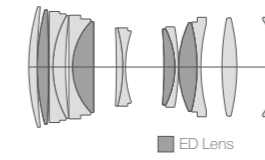
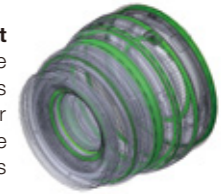

GF110mmF2 R LM WR

87mm (35mm format equivalent)

Lens configuration	14 elements in 9 groups (includes 4 extra-low dispersion elements)
Focal length (*)	f=110mm (87mm)
Angle of view	27.9°
Max. aperture	F2
Min. aperture	F22
Aperture control	Number of blades 9 (rounded diaphragm opening) Stop size 1/3EV (22 steps)
Focus range	0.9m - ∞
Max. magnification	0.16x
External dimension	φ94.3mm×125.5mm
Weight	1,010g (Excluding caps and hoods)
Filter size	φ77mm

*35mm format equivalent

GF23mmF4 R LM WR

18mm (35mm format equivalent)

Lens configuration	15 elements in 12 groups (includes 2 aspherical and 4 extra-low dispersion elements incl. 1 super ED lens)
Focal length (*)	f=23mm (18mm)
Angle of view	99.9°
Max. aperture	F4
Min. aperture	F32
Aperture control	Number of blades 9 (rounded diaphragm opening) Stop size 1/3EV (19 steps)
Focus range	38cm - ∞
Max. magnification	0.09x
External dimension	φ89.8mm×103mm
Weight	845g (Excluding caps and hoods)
Filter size	φ82mm

*35mm format equivalent

TO BE RELEASED IN 2017



GF45mmF2.8 R WR

36mm (35mm format equivalent)

Focal length (*)	f=45mm (36mm)
Angle of view	62.6°
Max. aperture	F2.8
Min. aperture	F32
Aperture control	Number of blades 9 (rounded diaphragm opening) Stop size 1/3EV (22 steps)
Focus range	45cm - ∞
Max. magnification	0.14x

*35mm format equivalent

* These specifications are as of Apr. 2017. Specifications are subject to change. * This is not the image of the final product.

●
FLASH

EF-X500 (Optional) A high performance, multi-function flash with a guide number of approx. 50, the optional EF-X500 supports multi-flash lighting, FP mode and continuous output in Burst Mode.



Guide Number	Approx. 50 (ISO100-m) / 164 (ISO100-ft)
Flash Coverage	24mm-105mm (35mm format equivalent), Auto Zoom Function, Approx. 20mm (35mm format equivalent) when using the Wide Panel
Bounce	90°up, 10°down, 135°left and 180°right
Color Temperature	Approx. 5600K (at Full Output)
FP (High Speed Flash Sync) Mode	Supported
Exposure Control System	TTL, Manual, Multi-Flash (Manual) TTL Compensation -5.0EV - +5.0EV at 1/3-step increments *This setting may not be reflected in some shooting conditions.
Manual Flash Power	1/1-1/512 at 1/3-step increments *Flash settings become slightly restricted in the FP mode.
Multi-Flash Power	1/4-1/512 at 1/3-step increments
Charge	
Firing Interval (at Full Power and Full Charge)	Approx. 2.5 seconds (Nickel-Hydrogen Battery)
Number of Flashes (at Full Power and Full Charge)	Approx. 170 times (Nickel-Hydrogen Battery)
Wireless Multi-Flash System	Communication Method Optical Transmission
Operation Modes	Master (TTL / Manual / Multi-Flash / OFF) Slave (TTL / Manual / Multi-Flash / OFF)
Communication Channels	Ch1 - 4
Slave Unit Groups	Up to 3 Groups (A / B / C)
Power Source	Four AA Batteries (LR6, or Ni-MH)
External Power Source	Battery Pack EF-BP1 (Optional)
Dimensions	Approx. 124.0mm (H) x 67.2mm (W) x 107.3mm (D)
Weight	Approx. 380g (Excluding Batteries)

●
TERMINAL

External Connection Interface The GFX 50S offers various interfacing options, including USB 3.0 for computer-tethered shooting, an HDMI Micro connector to output images to an external monitor, remote shutter release terminal, microphone input, and headphone jack. Connect the optional AC power adapter AC-15V to the DC input terminal to use an external power source for camera operation and charging. The camera comes with a cable lock for attaching cables.



Digital Interface	USB 3.0 (High-Speed) / Micro USB Terminal *Connectable with Remote Release RR-90 (Optional)
	HDMI Output HDMI Micro Connector (Type D)
	DC IN 15V Connector *Compatible with AC-15V (Optional) Only
	ø2.5mm, Remote Release Connector
	ø3.5mm, Stereo Mini Connector (Microphone)
	ø3.5mm, Stereo Mini Connector (Headphone)
Others	Hot Shoe, Synchronized Terminal

●
MOUNT ADAPTER

H MOUNT ADAPTER G (Optional) Enables compatibility with H Mount lenses, including SUPER EBC FUJINON HC lenses for GX645AF (discontinued), to be attached to the GFX 50S. It supports lens shutter operations and aperture priority AE. Focusing is manual only, but the mount features electronic contacts to generate and record lens correction data for individual lenses. And a detachable tripod base plate is included.



Compatible Lens	H Mount Lens
Exposure Mode	Aperture Priority AE (A) and Manual
Shutter Select	Camera Body Focal-Plane Shutter / Leaf Shutter in Lens
Focus Mode	Manual Focus Only
Operation Parts	Fn button (Shutter Select), Mount Release Lever, Detachable Tripod base plate

●
VIEW CAMERA ADAPTER

VIEW CAMERA ADAPTER G (Optional) Allows you to use a 4x5 view camera on the GFX 50S in conjunction with old large format FUJINON lenses. This allows you to take advantage of a view camera's characteristic tilt and shift functions while using the focal-plane shutter in the camera body.



Compatible Body	International Standard 4x5 Camera*
Operation Parts	±20mm Horizontal Shift Slider (5.0mm step)
Mount Rotatable	0° / 90° / 180° / 270°

*Depending on body shape, this adapter may not be attached.

TETHERED SHOOTING

HS-V5 (Optional) Use HS-V5 for Windows® software to tether the GFX 50S using a USB cable. This enables you to directly save pictures on to a computer or control the camera from the computer. The Hyper-Utility3 software, which comes with the camera, allows you to view the photographs you have taken on your computer. With the software, you can analyze images based on information it displays such as histogram, highlight warnings and tags, evaluate images by displaying two images side by side for comparison and sort/organize images with the Marker function.

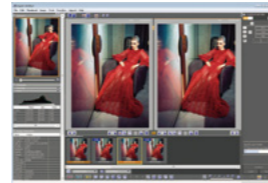

Tether Shooting Plug-in PRO for Adobe® Photoshop® Lightroom® (optional)* A plug-in to allow Adobe® Photoshop® Lightroom® users to tether the GFX 50S to a computer, using a USB cable or via Wi-Fi®** (Firmware Ver.1.10 or later) and directly save pictures on the computer or control the camera from it. In addition to the functions available in the standard version of the Tether Shooting Plug-in for Adobe® Photoshop® Lightroom®, this PRO version allows you to view the photographs you have taken on your computer, and displays the Control Panel window on the computer to enable a variety of camera controls. The conventional Lightroom tethering plug-in forces you to wait until your picture is transferred, saved and registered with Lightroom before it is displayed on the screen for checking. The Control Panel window in the PRO version displays pictures faster for quick viewing. The Control Panel window also supports Live View as well as offers a multitude of camera controls such as exposure settings, bracketing, interval photography, overlay check and backup / restoration of camera settings.

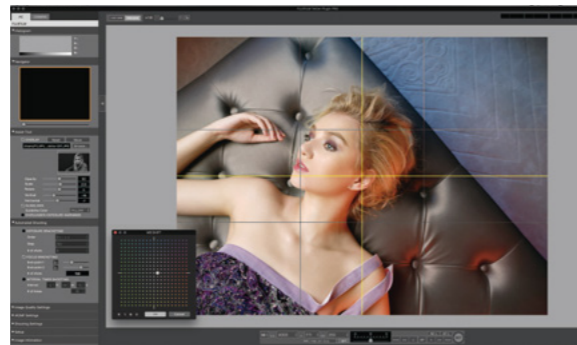

*Adobe® Photoshop® Lightroom® 6 or CC is required. The compatible OS is same as that of Lightroom. To use on macOS Sierra, Lightroom should be upgraded to 6.7 or later / CC 2015.7 or later.

**Wi-Fi® is a registered trademark of the Wi-Fi Alliance.

RAW CONVERSION

In-Camera RAW Conversion Function The GFX 50S features in-camera RAW conversion capability. RAW conversion can be performed in the field without a computer. Exposure compensation, white balance, image quality and other in-camera settings can all be easily changed. You can even apply a Film Simulation mode of your choice to RAW images. Processed RAW files are saved as a JPEG or 8-bit TIFF.

Adobe® Photoshop® Lightroom® / Adobe® Photoshop® CC (Optional) Use Adobe® Photoshop® Lightroom® or Adobe® Photoshop® CC to process your RAW files and save them as JPEG, TIFF, etc. on your computer. It allows more refined or bolder adjustments than the in-camera RAW Converter and maintains the use of Film Simulation modes.



RAW FILE CONVERTER EX 2.0 powered by SILKYPIX (Free Download) Use the RAW FILE CONVERTER EX 2.0 powered by SILKYPIX to convert RAW files taken with the GFX 50S. Various image settings and Film Simulation modes can be altered.



GF63mmF2.8 R WR on FUJIFILM GFX 50S 1/800sec, F2.8 ISO400 ASTIA Photographer: Natan Sans

SYSTEM CHART

REMOTE RELEASE
RR-90



STEREO MICROPHONE
MIC-ST1



CLIP ON FLASH
EF-X500 [Weather Resistant]



CABLE LOCK
[Included]



HOT SHOE COVER
[Included]



EVF TILT ADAPTER
EVF-TL1 [Weather Resistant]



EYE CUP



LENS



AC POWER ADAPTER
AC-15V



BATTERY
NP-T125



SD CARD



BODY
GFX50S [Weather Resistant]



PROTECTOR FILTER
PRF-62 / PRF-72 / PRF-77 / PRF-82



GF23mmF4 R LM WR



GF45mmF2.8 R WR



GF63mmF2.8 R WR

BATTERY CHARGER
BC-T125 [4 types of plugs included]



VERTICAL BATTERY GRIP
VG-GFX1 [Weather Resistant]



SHOULDER STRAP
METAL STRAP CLIP
METAL STRAP CLIP LOCK
[Included]



MOUNT ADAPTER
H MOUNT ADAPTER G
[Tripod base plate included]



VIEW CAMERA ADAPTER
VIEW CAMERA ADAPTER G

